



National
Qualifications
2016

X757/75/02

Physics
Section 1 — Questions

TUESDAY, 24 MAY

1:00 PM – 3:00 PM

Instructions for the completion of Section 1 are given on *Page 02* of your question and answer booklet X757/75/01.

Record your answers on the answer grid on *Page 03* of your question and answer booklet

Reference may be made to the Data Sheet on *Page 02* of this booklet and to the Relationships Sheet X757/75/11.

Before leaving the examination room you must give your question and answer booklet to the Invigilator; if you do not, you may lose all the marks for this paper.



* X 7 5 7 7 5 0 2 *

DATA SHEET

Speed of light in materials

Material	Speed in m s^{-1}
Air	3.0×10^8
Carbon dioxide	3.0×10^8
Diamond	1.2×10^8
Glass	2.0×10^8
Glycerol	2.1×10^8
Water	2.3×10^8

Speed of sound in materials

Material	Speed in m s^{-1}
Aluminium	5200
Air	340
Bone	4100
Carbon dioxide	270
Glycerol	1900
Muscle	1600
Steel	5200
Tissue	1500
Water	1500

Gravitational field strengths

	Gravitational field strength on the surface in N kg^{-1}
Earth	9.8
Jupiter	23
Mars	3.7
Mercury	3.7
Moon	1.6
Neptune	11
Saturn	9.0
Sun	270
Uranus	8.7
Venus	8.9

Specific heat capacity of materials

Material	Specific heat capacity in $\text{J kg}^{-1} \text{ }^\circ\text{C}^{-1}$
Alcohol	2350
Aluminium	902
Copper	386
Glass	500
Ice	2100
Iron	480
Lead	128
Oil	2130
Water	4180

Specific latent heat of fusion of materials

Material	Specific latent heat of fusion in J kg^{-1}
Alcohol	0.99×10^5
Aluminium	3.95×10^5
Carbon Dioxide	1.80×10^5
Copper	2.05×10^5
Iron	2.67×10^5
Lead	0.25×10^5
Water	3.34×10^5

Melting and boiling points of materials

Material	Melting point in $^\circ\text{C}$	Boiling point in $^\circ\text{C}$
Alcohol	-98	65
Aluminium	660	2470
Copper	1077	2567
Glycerol	18	290
Lead	328	1737
Iron	1537	2737

Specific latent heat of vaporisation of materials

Material	Specific latent heat of vaporisation in J kg^{-1}
Alcohol	11.2×10^5
Carbon Dioxide	3.77×10^5
Glycerol	8.30×10^5
Turpentine	2.90×10^5
Water	22.6×10^5

Radiation weighting factors

Type of radiation	Radiation weighting factor
alpha	20
beta	1
fast neutrons	10
gamma	1
slow neutrons	3
X-rays	1

SECTION 1

Attempt ALL questions

1. The symbol for an electronic component is shown.

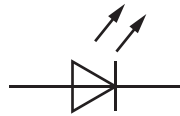

This is the symbol for

- A an LDR
 - B a transistor
 - C an LED
 - D a photovoltaic cell
 - E a thermistor.
2. A uniform electric field exists between plates Q and R.
The diagram shows the path taken by a particle as it passes through the field.

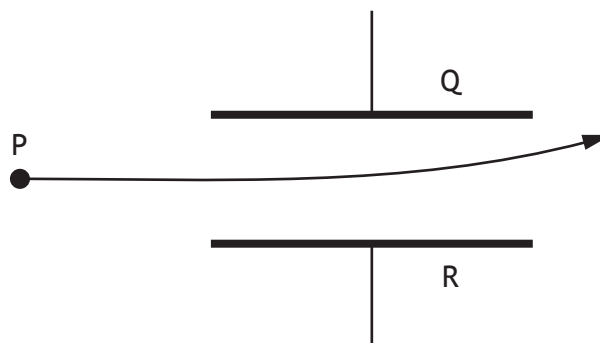

Which row in the table identifies the charge on the particle, the charge on plate Q and the charge on plate R?

	<i>Charge on particle</i>	<i>Charge on plate Q</i>	<i>Charge on plate R</i>
A	negative	positive	negative
B	negative	negative	positive
C	no charge	negative	positive
D	no charge	positive	negative
E	positive	positive	negative

3. A circuit is set up as shown.

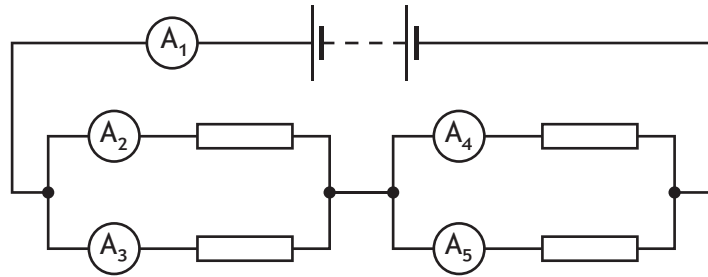

The reading on ammeter A_1 is 5.0 A .

The reading on ammeter A_2 is 2.0 A .

The reading on ammeter A_4 is 1.0 A .

Which row in the table shows the reading on ammeters A_3 and A_5 ?

	Reading on ammeter A_3 (A)	Reading on ammeter A_5 (A)
A	2.0	1.0
B	3.0	1.0
C	2.0	4.0
D	3.0	4.0
E	5.0	5.0

4. Two resistors are connected as shown.

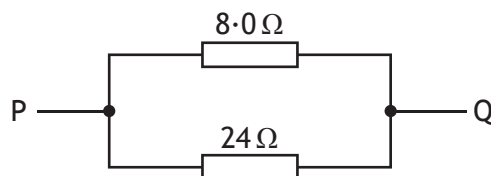

The total resistance between P and Q is

- A $0.17\ \Omega$
- B $3.0\ \Omega$
- C $6.0\ \Omega$
- D $16\ \Omega$
- E $32\ \Omega$.

5. A block has the dimensions shown.

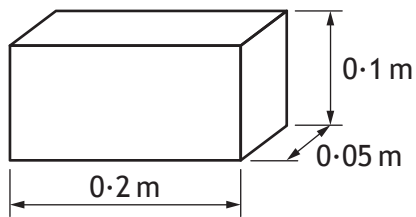

The block is placed so that one of the surfaces is in contact with a smooth table top.

The weight of the block is 4.90 N.

The **minimum** pressure exerted by the block on the table top is

- A 25 Pa
 - B 245 Pa
 - C 490 Pa
 - D 980 Pa
 - E 4900 Pa.
6. A syringe is connected to a pressure meter as shown.

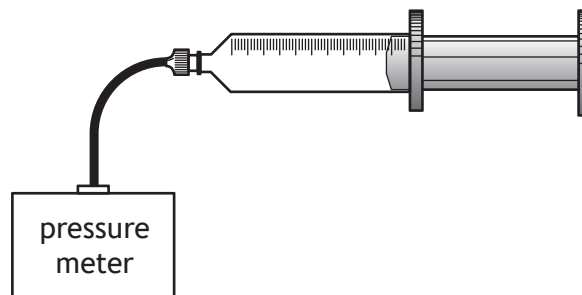

The syringe contains a fixed mass of air of volume 150 mm^3 .

The reading on the pressure meter is 120 kPa.

The volume of air inside the syringe is now changed to 100 mm^3 .

The temperature of the air in the syringe remains constant.

The reading on the pressure meter is now

- A 80 kPa
- B 125 kPa
- C 180 kPa
- D 80 000 kPa
- E 180 000 kPa.

7. A sample of an ideal gas is enclosed in a sealed container.

Which graph shows how the pressure p of the gas varies with the temperature T of the gas?

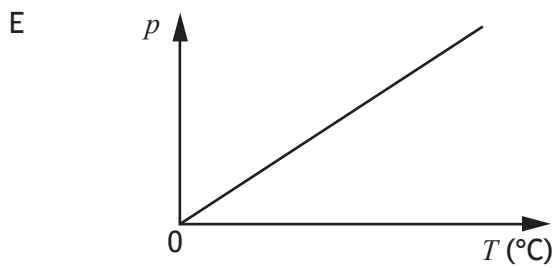
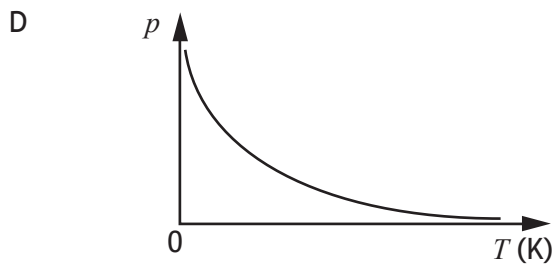
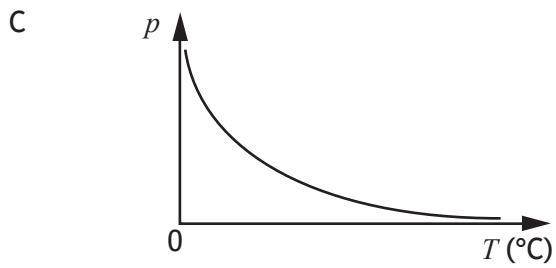
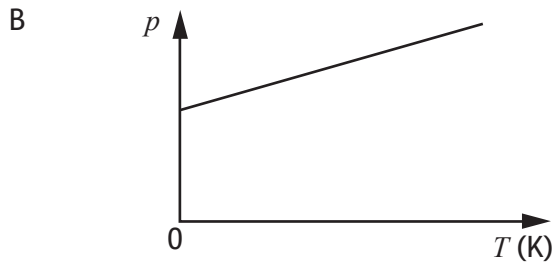
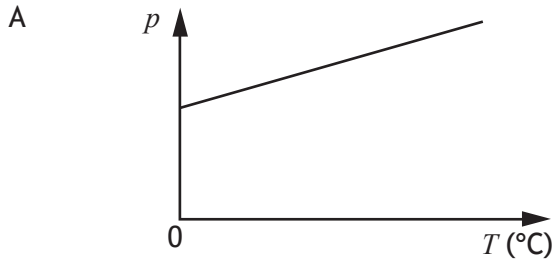

8. A student makes the following statements about waves.

- I Waves transfer energy.
- II A wave with a short wavelength diffracts more than a wave with a long wavelength.
- III The amplitude of a wave depends on its wavelength.

Which of these statements is/are correct?

- A I only
- B II only
- C III only
- D I and II only
- E I and III only

9. The diagram represents a wave.

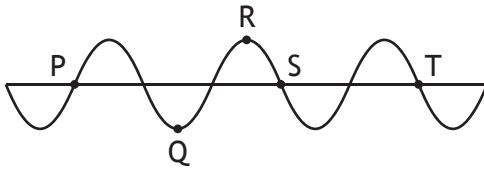

The wavelength of the wave is the horizontal distance between points

- A P and Q
- B P and S
- C Q and R
- D R and S
- E S and T.

[Turn over

10. The diagram represents the position of the crests of waves 3 seconds after a stone is thrown into a pool of still water.

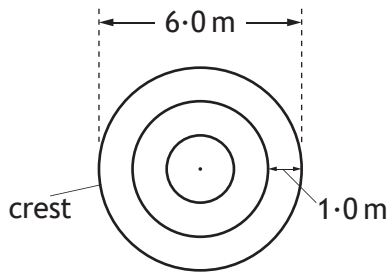

Which row in the table shows the speed and the frequency of the waves?

	<i>Speed</i> (m s ⁻¹)	<i>Frequency</i> (Hz)
A	0.33	3
B	0.33	1
C	1.0	1
D	1.0	3
E	1.0	4

11. A ray of red light passes through a double glazed window.
Which diagram shows the path of the ray as it passes through the window?

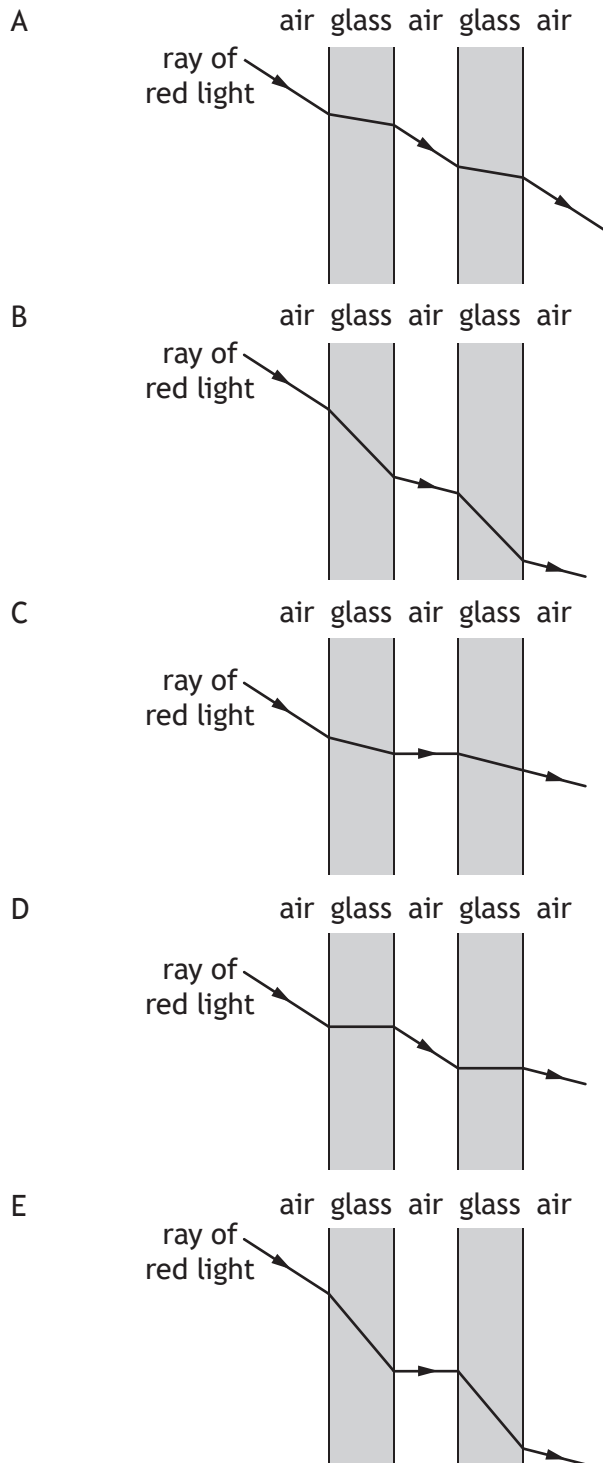

[Turn over

12. Which row in the table shows how the mass and charge of an alpha particle compares to the mass and charge of a beta particle?

	<i>Mass of an alpha particle compared to mass of a beta particle</i>	<i>Charge on an alpha particle compared to charge on a beta particle</i>
A	larger	same
B	larger	opposite
C	same	same
D	smaller	opposite
E	smaller	same

13. During ionisation an atom becomes a positive ion.
Which of the following has been removed from the atom?

- A An alpha particle
- B An electron
- C A gamma ray
- D A neutron
- E A proton

14. Which of the following is a vector quantity?

- A Mass
- B Time
- C Speed
- D Kinetic energy
- E Acceleration

15. A ball moves along a horizontal frictionless surface and down a slope as shown.

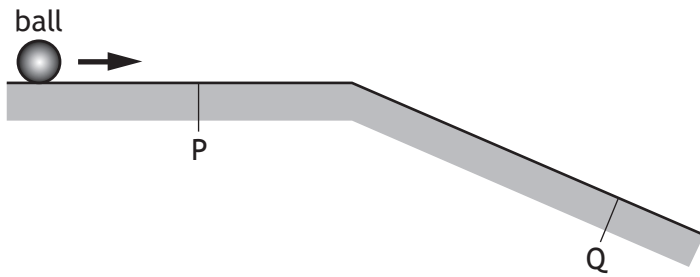

Which of the following graphs shows how the speed of the ball varies with time as it travels from P to Q?

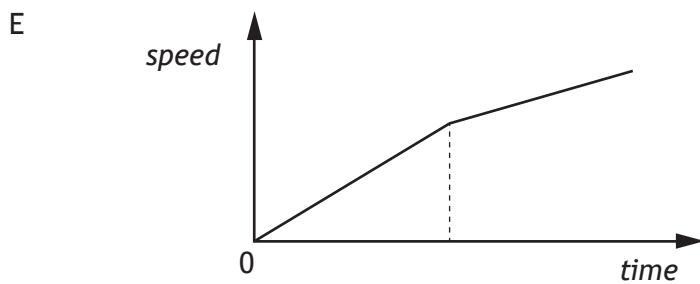
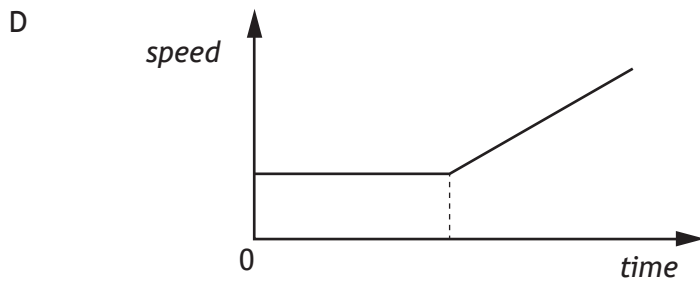
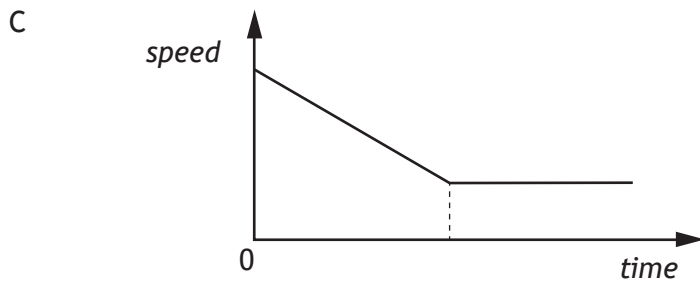
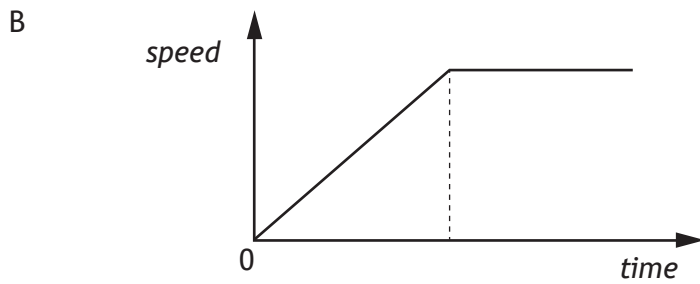
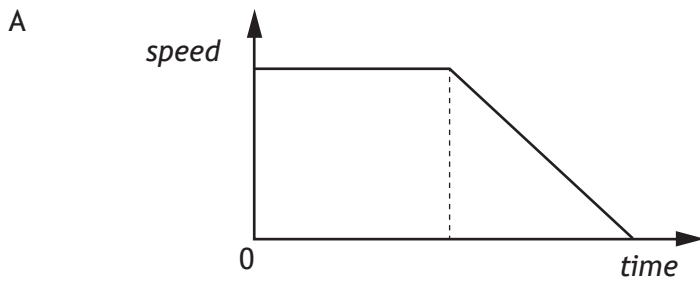

16. A cyclist is travelling at 10 m s^{-1} along a level road.
The cyclist applies the brakes and comes to rest in a time of 5 s.
The combined mass of the cycle and cyclist is 80 kg.
The maximum energy converted to heat by the brakes is
- A 160 J
 - B 400 J
 - C 800 J
 - D 4000 J
 - E 8000 J.
17. A rocket is taking off from the surface of the Earth. The rocket engines exert a force on the exhaust gases.
Which of the following is the reaction to this force?
- A The force of the Earth on the exhaust gases.
 - B The force of the Earth on the rocket engines.
 - C The force of the rocket engines on the Earth.
 - D The force of the exhaust gases on the Earth.
 - E The force of the exhaust gases on the rocket engines.

18. A ball is projected horizontally with a velocity of 1.5 m s^{-1} from a cliff as shown.

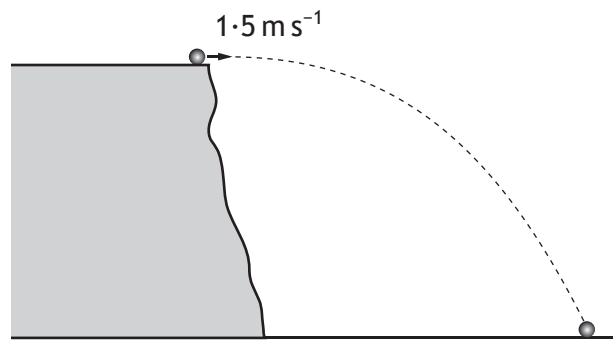

The ball hits the ground 1.2 s after it leaves the cliff.

The effects of air resistance are negligible.

Which row in the table shows the horizontal velocity and vertical velocity of the ball just before it hits the ground?

	<i>Horizontal velocity</i> (m s^{-1})	<i>Vertical velocity</i> (m s^{-1})
A	12	12
B	12	1.5
C	1.5	12
D	1.5	13
E	0	12

19. The minimum amount of energy required to change 0.5 kg of water at its boiling point into steam at the same temperature is

- A $2.09 \times 10^3 \text{ J}$
- B $1.67 \times 10^5 \text{ J}$
- C $3.34 \times 10^5 \text{ J}$
- D $1.13 \times 10^6 \text{ J}$
- E $2.26 \times 10^6 \text{ J}$.

20. A student makes the following statements about the Universe.

- I The Big Bang Theory is a theory about the origin of the Universe.
- II The Universe is approximately 14 million years old.
- III The Universe is expanding.

Which of these statements is/are correct?

- A I only
- B II only
- C I and II only
- D I and III only
- E I, II and III.

**[END OF SECTION 1. NOW ATTEMPT THE QUESTIONS IN SECTION 2 OF
YOUR QUESTION AND ANSWER BOOKLET]**

[BLANK PAGE]

DO NOT WRITE ON THIS PAGE

[BLANK PAGE]

DO NOT WRITE ON THIS PAGE

FOR OFFICIAL USE



National
Qualifications
2016

Mark

X757/75/01

**Physics
Section 1 — Answer Grid
and Section 2**

TUESDAY, 24 MAY

1:00 PM – 3:00 PM



* X 7 5 7 7 5 0 1 *

Fill in these boxes and read what is printed below.

Full name of centre

Town

Forename(s)

Surname

Number of seat

Date of birth

Day

Month

Year

Scottish candidate number

Total marks — 110

SECTION 1 — 20 marks

Attempt ALL questions.

Instructions for completion of Section 1 are given on *Page 02*.

SECTION 2 — 90 marks

Attempt ALL questions.

Reference may be made to the Data Sheet on *Page 02* of the question paper X757/75/02 and to the Relationships Sheet X757/75/11.

Write your answers clearly in the spaces provided in this booklet. Additional space for answers and rough work is provided at the end of this booklet. If you use this space you must clearly identify the question number you are attempting. Any rough work must be written in this booklet. You should score through your rough work when you have written your final copy.

Use **blue** or **black** ink.

Before leaving the examination room you must give this booklet to the Invigilator; if you do not, you may lose all the marks for this paper.



* X 7 5 7 7 5 0 1 0 1 *

The questions for Section 1 are contained in the question paper X757/75/02.

Read these and record your answers on the answer grid on *Page 03* opposite.

Use **blue** or **black** ink. Do NOT use gel pens or pencil.

1. The answer to each question is **either** A, B, C, D or E. Decide what your answer is, then fill in the appropriate bubble (see sample question below).
2. There is **only one correct** answer to each question.
3. Any rough work must be written in the additional space for answers and rough work at the end of this booklet.

Sample Question

The energy unit measured by the electricity meter in your home is the:

- A ampere
- B kilowatt-hour
- C watt
- D coulomb
- E volt.

The correct answer is **B** — kilowatt-hour. The answer **B** bubble has been clearly filled in (see below).

A	B	C	D	E
<input type="radio"/>	<input checked="" type="radio"/>	<input type="radio"/>	<input type="radio"/>	<input type="radio"/>

Changing an answer

If you decide to change your answer, cancel your first answer by putting a cross through it (see below) and fill in the answer you want. The answer below has been changed to **D**.

A	B	C	D	E
<input type="radio"/>	<input checked="" type="radio"/>	<input type="radio"/>	<input checked="" type="radio"/>	<input type="radio"/>

If you then decide to change back to an answer you have already scored out, put a tick (✓) to the **right** of the answer you want, as shown below:

A	B	C	D	E	or	A	B	C	D	E
<input type="radio"/>	<input checked="" type="radio"/>	<input type="radio"/>	<input checked="" type="radio"/>	<input type="radio"/>		<input type="radio"/>	<input checked="" type="radio"/>	<input type="radio"/>	<input type="radio"/>	<input type="radio"/>



SECTION 1 — Answer Grid



	A	B	C	D	E
1	<input type="radio"/>	<input type="radio"/>	<input type="radio"/>	<input type="radio"/>	<input type="radio"/>
2	<input type="radio"/>	<input type="radio"/>	<input type="radio"/>	<input type="radio"/>	<input type="radio"/>
3	<input type="radio"/>	<input type="radio"/>	<input type="radio"/>	<input type="radio"/>	<input type="radio"/>
4	<input type="radio"/>	<input type="radio"/>	<input type="radio"/>	<input type="radio"/>	<input type="radio"/>
5	<input type="radio"/>	<input type="radio"/>	<input type="radio"/>	<input type="radio"/>	<input type="radio"/>
6	<input type="radio"/>	<input type="radio"/>	<input type="radio"/>	<input type="radio"/>	<input type="radio"/>
7	<input type="radio"/>	<input type="radio"/>	<input type="radio"/>	<input type="radio"/>	<input type="radio"/>
8	<input type="radio"/>	<input type="radio"/>	<input type="radio"/>	<input type="radio"/>	<input type="radio"/>
9	<input type="radio"/>	<input type="radio"/>	<input type="radio"/>	<input type="radio"/>	<input type="radio"/>
10	<input type="radio"/>	<input type="radio"/>	<input type="radio"/>	<input type="radio"/>	<input type="radio"/>
11	<input type="radio"/>	<input type="radio"/>	<input type="radio"/>	<input type="radio"/>	<input type="radio"/>
12	<input type="radio"/>	<input type="radio"/>	<input type="radio"/>	<input type="radio"/>	<input type="radio"/>
13	<input type="radio"/>	<input type="radio"/>	<input type="radio"/>	<input type="radio"/>	<input type="radio"/>
14	<input type="radio"/>	<input type="radio"/>	<input type="radio"/>	<input type="radio"/>	<input type="radio"/>
15	<input type="radio"/>	<input type="radio"/>	<input type="radio"/>	<input type="radio"/>	<input type="radio"/>
16	<input type="radio"/>	<input type="radio"/>	<input type="radio"/>	<input type="radio"/>	<input type="radio"/>
17	<input type="radio"/>	<input type="radio"/>	<input type="radio"/>	<input type="radio"/>	<input type="radio"/>
18	<input type="radio"/>	<input type="radio"/>	<input type="radio"/>	<input type="radio"/>	<input type="radio"/>
19	<input type="radio"/>	<input type="radio"/>	<input type="radio"/>	<input type="radio"/>	<input type="radio"/>
20	<input type="radio"/>	<input type="radio"/>	<input type="radio"/>	<input type="radio"/>	<input type="radio"/>



[BLANK PAGE]

DO NOT WRITE ON THIS PAGE



* X 7 5 7 7 5 0 1 0 4 *

[TURN OVER FOR NEXT QUESTION

DO NOT WRITE ON THIS PAGE



* X 7 5 7 7 5 0 1 0 5 *

SECTION 2 — 90 marks
Attempt ALL questions

1. Electrical storms occur throughout the world.



During one lightning strike 24 C of charge is transferred to the ground in 0.0012 s .

- (a) Calculate the average current during the lightning strike.

3

Space for working and answer

- (b) The charge on an electron is $-1.6 \times 10^{-19}\text{ C}$.

Determine the number of electrons transferred during the lightning strike.

1

Space for working and answer



1. (continued)

- (c) Many tall buildings have a thick strip of metal attached to the side of the building.

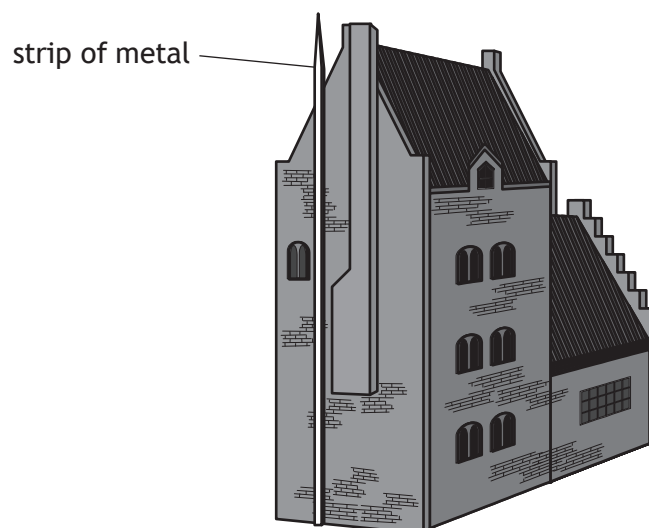

This strip is used to protect the building from damage during electrical storms.

Explain how this strip protects the building from damage.

2



* X 7 5 7 7 5 0 1 0 7 *

2. A student investigates the resistance of a resistor using the circuit shown.

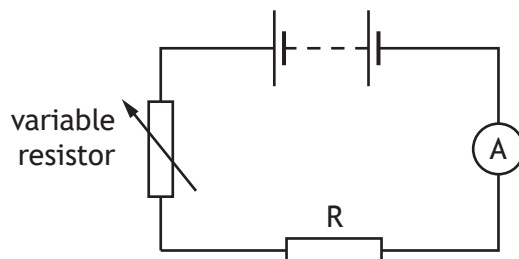

- (a) Complete the circuit diagram to show where a voltmeter must be connected to measure the voltage across resistor R. 1
 (An additional diagram, if required, can be found on Page 33.)
- (b) Describe how the student obtains a range of values of voltage and current. 1

2. (continued)

(c) The results of the student's investigation are shown.

<i>Voltage across resistor R (V)</i>	<i>Current in resistor R (A)</i>
1.0	0.20
2.5	0.50
3.2	0.64
6.2	1.24

Use all these results to determine the resistance of resistor R.

4

Space for working and answer

(d) The student now replaces resistor R with a filament lamp and repeats the investigation. A sketch graph of the student's results is shown.

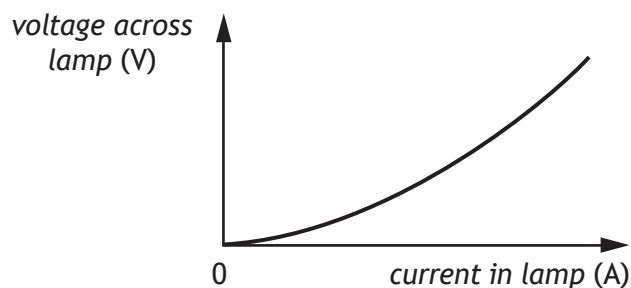

State a conclusion that can be made about the resistance of the filament lamp.

1



3. A washing machine fills with water at a temperature of 15.0°C .
The water is heated by a heating element.

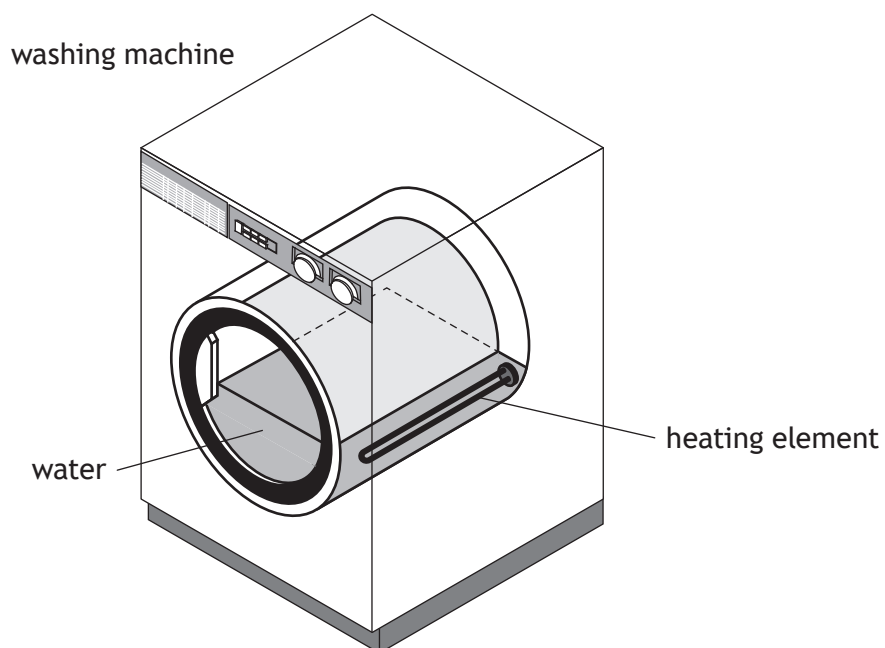

- (a) The mass of the water in the washing machine is 6.00 kg .
Show that the minimum energy required to increase the temperature of the water from 15.0°C to 40.0°C is $627\,000\text{ J}$.
Space for working and answer

2

3. (continued)

(b) The heating element has a power rating of 1800 W.

- (i) Calculate the time taken for the heating element to supply the energy calculated in (a).

3

Space for working and answer

- (ii) Explain why, in practice, it takes longer to heat the water from 15 °C to 40 °C than calculated in (b)(i).

1



* X 7 5 7 7 5 0 1 1 1 *

3. (continued)

- (c) The temperature of the water in the washing machine is monitored by a circuit containing a thermistor.

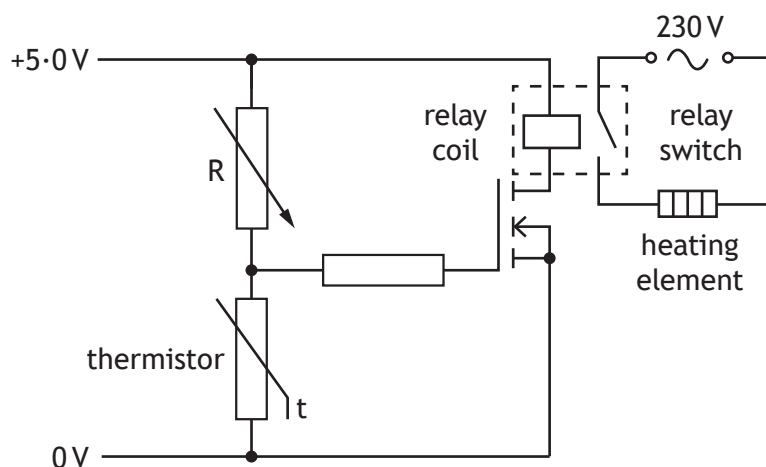

As the temperature of the water increases, the resistance of the thermistor decreases.

The heating element is switched off when the temperature of the water reaches 40°C.

Explain how the circuit operates to **switch off** the heating element.

3

4. The diagram shows some parts of the electromagnetic spectrum in order of increasing wavelength.

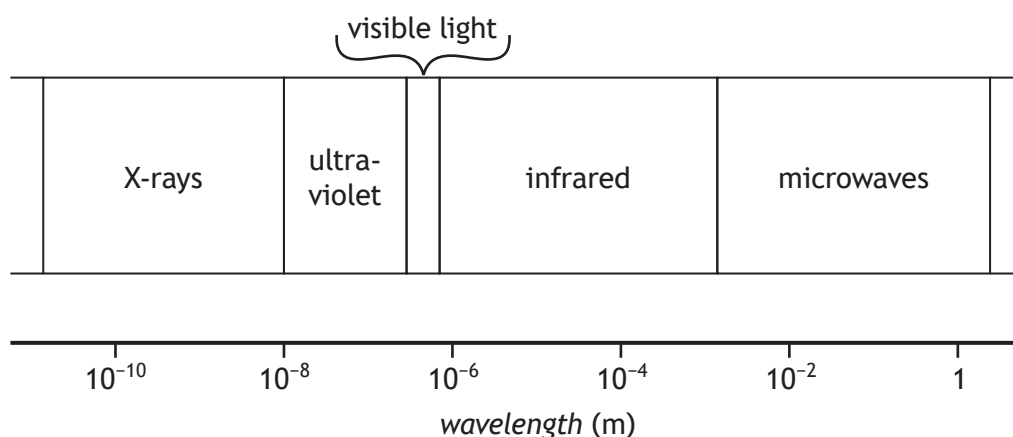

- (a) State a detector of infrared radiation. 1
- (b) State which radiation in the electromagnetic spectrum has a wavelength shorter than X-rays. 1
- (c) (i) An electromagnetic wave has a frequency of 1.2 GHz.
Show that the wavelength of this wave is 0.25 m. 2
Space for working and answer
- (ii) Identify the part of the spectrum that this wave belongs to. 1



[BLANK PAGE]

DO NOT WRITE ON THIS PAGE



* X 7 5 7 7 5 0 1 1 4 *

MARKS

DO NOT
WRITE IN
THIS
MARGIN

5. A Physics textbook contains the following statement.

“Electromagnetic waves can be sent out like ripples on a pond.”

Using your knowledge of physics, comment on the similarities and/or differences between electromagnetic waves and the ripples on a pond.

3



* X 7 5 7 7 5 0 1 1 5 *

6. A student directs a ray of red light into a Perspex block to investigate refraction.

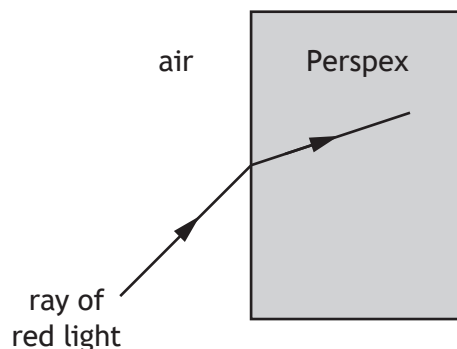

- (a) On the diagram, draw and label:

(i) the normal;

1

(ii) the angle of incidence i and the angle of refraction r .

1

(An additional diagram, if required, can be found on *Page 33*)

- (b) The student varies the angle of incidence and measures the corresponding angles of refraction. The results are plotted on a graph.

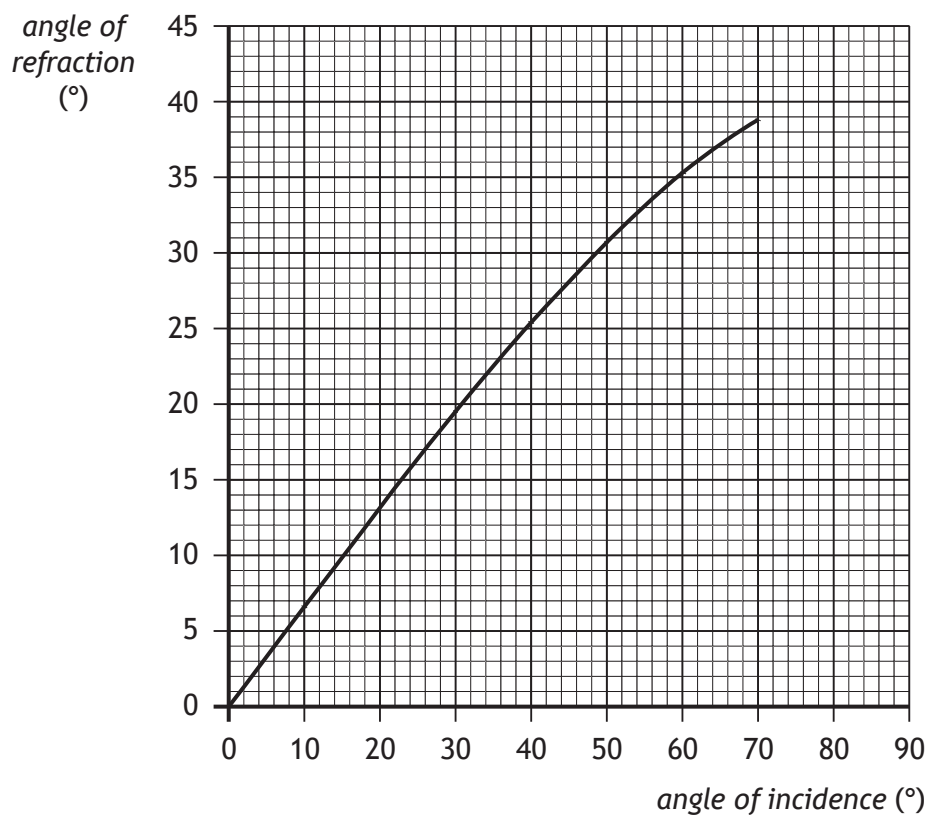

6. (b) (continued)

- (i) Determine the angle of refraction when the angle of incidence is 12° . 1
- (ii) Use the graph to predict the angle of refraction the student would obtain for an angle of incidence of 80° . 1
- (c) Suggest why it would be good practice for the student to repeat the investigation a further three or four times. 1



7. A spacecraft uses a radioisotope thermoelectric generator (RTG) as a power source.

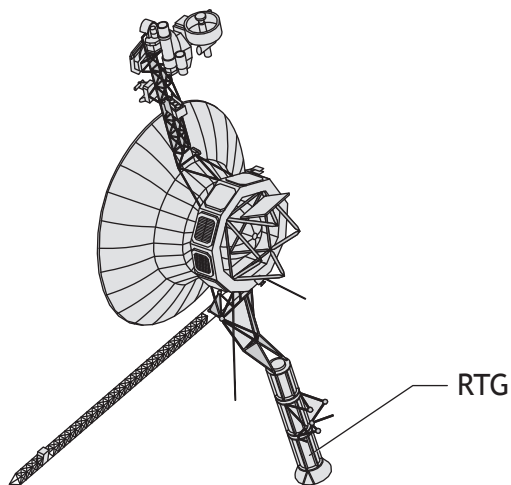

The RTG transforms the heat released by the radioactive decay of plutonium-238 into electrical energy.

- (a) In 15 minutes, 7.92×10^{18} nuclei of plutonium-238 decay.

Calculate the activity of the plutonium-238.

3

Space for working and answer

- (b) Each decay produces heat that is transformed into 4.49×10^{-14} J of electrical energy.

Determine the power output of the RTG.

2

Space for working and answer



MARKS

DO NOT
WRITE IN
THIS
MARGIN

7. (continued)

- (c) Plutonium-238 emits alpha radiation.

Explain why a source that emits alpha radiation requires less shielding than a source that emits gamma radiation.

1



* X 7 5 7 7 5 0 1 1 9 *

8. During medical testing a beta source is used to irradiate a sample of tissue of mass 0.50 kg from a distance of 0.10 m .

The sample absorbs $9.6 \times 10^{-5} \text{ J}$ of energy from the beta source.

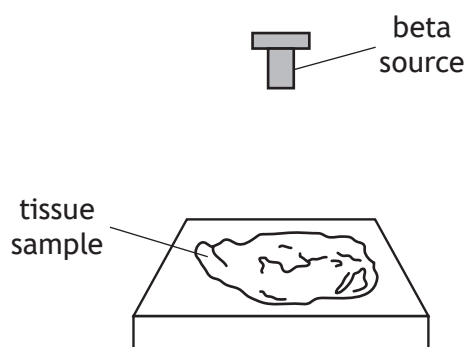

- (a) (i) Calculate the absorbed dose received by the sample.

3

Space for working and answer

- (ii) Calculate the equivalent dose received by the sample.

3

Space for working and answer



MARKS

DO NOT
WRITE IN
THIS
MARGIN

8. (continued)

(b) The beta source used during testing has a half-life of 36 hours.

The initial activity of the beta source is 12 kBq.

Determine the activity of the source 144 hours later.

Space for working and answer

3



* X 7 5 7 7 5 0 1 2 1 *

9. A student walks around a building from point X to point Y.

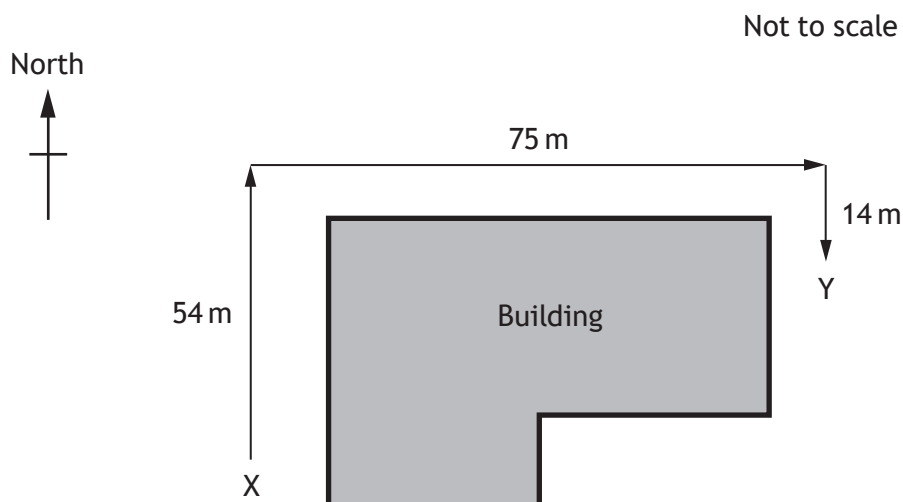

(a) By scale diagram, or otherwise, determine:

- (i) the magnitude of the displacement of the student from point X to point Y;

2

Space for working and answer

- (ii) the direction of displacement of the student from point X to point Y.

2

Space for working and answer



9. (continued)

(b) The student takes 68 s to travel from point X to point Y.

- (i) Determine the average velocity of the student from point X to point Y.

3

Space for working and answer

- (ii) The student states that their average speed between point X and point Y is greater than the magnitude of their average velocity between point X and point Y.

Explain why the student is correct.

2



10. An air descender is a machine that controls the rate at which a climber drops from a platform at the top of a climbing wall.

A climber, attached to the air descender by a rope, steps off the platform and drops towards the ground and lands safely.

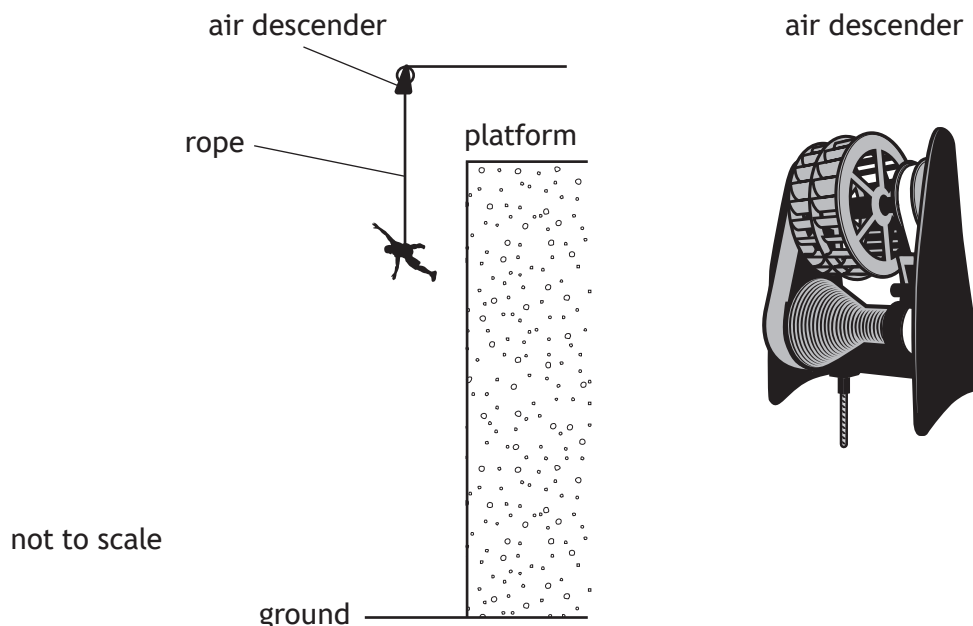

The graph shows how the vertical velocity of the climber varies with time from the instant the climber leaves the platform until landing.

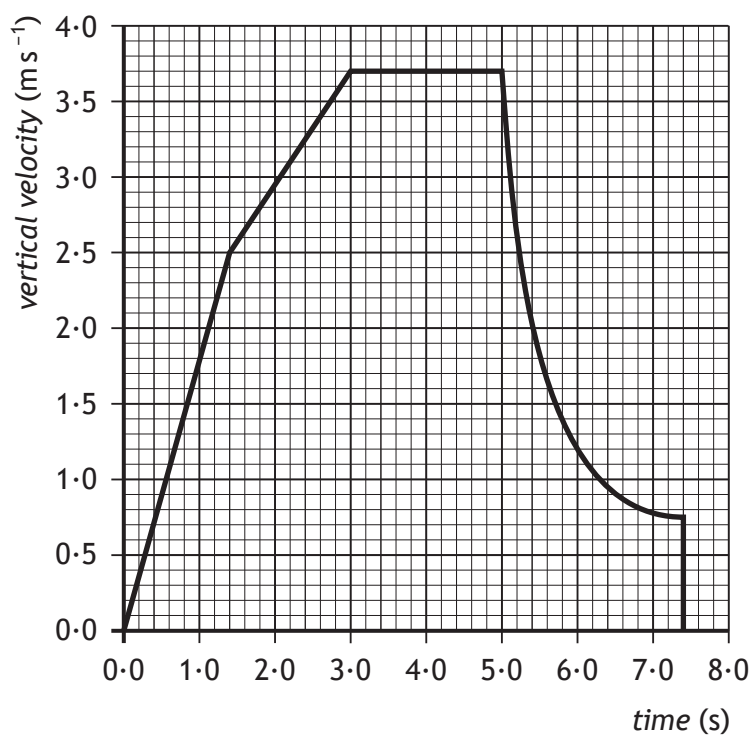

10. (continued)

- (a) Calculate the acceleration of the climber during the first 1.4 s of the drop.

3

Space for working and answer

- (b) Calculate the distance the climber drops during the first 3.0 s.

3

Space for working and answer

- (c) During part of the drop the forces on the climber are balanced.

On the diagram below show all the forces acting vertically on the climber during this part of the drop.

You must name these forces **and** show their directions.

3

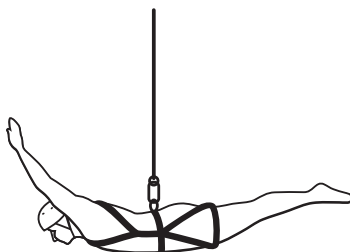

(An additional diagram, if required, can be found on Page 33)



[BLANK PAGE]

DO NOT WRITE ON THIS PAGE



* X 7 5 7 7 5 0 1 2 6 *

11. The length of runway required for aircraft to lift off the ground into the air is known as the ground roll.

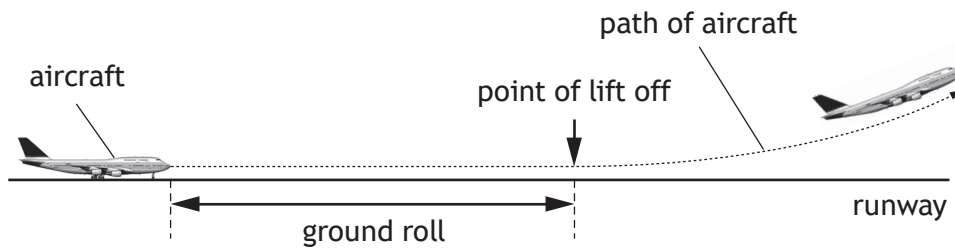

The ground roll of an aircraft varies for each take-off.

Use your knowledge of physics to comment on why the ground roll of an aircraft varies for each take-off.

3



12. On 12th November 2014, on a mission known as Rosetta, the European Space Agency successfully landed a probe on the surface of a comet.

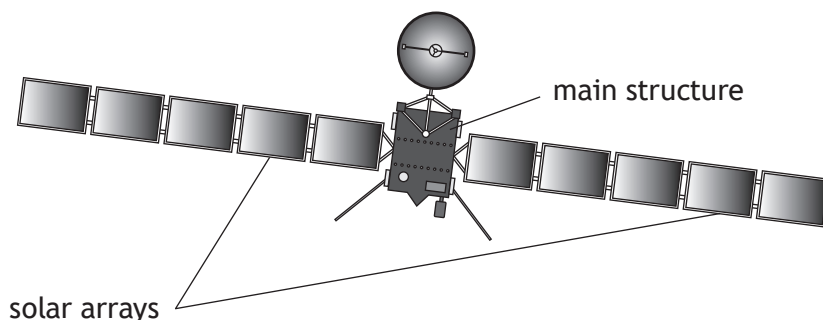

The main structure of the Rosetta spacecraft consists of an orbiter, a lander and propellant.

Rosetta spacecraft data		
Launch mass	Orbiter	1.23×10^3 kg
	Lander	0.10×10^3 kg
	Propellant	1.67×10^3 kg
	Total	3.00×10^3 kg
Energy source	Solar array output	850 W at 3.4 AU 395 W at 5.25 AU
Trajectory control	24 Thrusters	10 N of force each

- (a) Calculate the total weight of the spacecraft on Earth. 3
Space for working and answer
- (b) The solar arrays contain photovoltaic cells.
- (i) State the energy change in a photovoltaic cell. 1
- (ii) Suggest why the solar arrays were designed so that they can rotate. 1



12. (b) (continued)

- (iii) Calculate the total energy output of the solar arrays when operating at 5.25 AU for 2 hours.

3

Space for working and answer

- (c) At a point on its journey between Earth and the comet, the spacecraft was travelling at a constant velocity.

- (i) The spacecraft switched on four of its thrusters to accelerate it in the direction of travel.

The four thrusters exerted a force on the spacecraft in the same direction.

Determine the total force produced by these thrusters.

1

Space for working and answer

- (ii) At this point, the spacecraft had used 1.00×10^3 kg of propellant.

Calculate the acceleration of the spacecraft.

4

Space for working and answer



* X 7 5 7 7 5 0 1 2 9 *

13. Read the passage and answer the questions that follow.

Supernova explosion



The average temperature of the surface of the Sun is 5778 K. In the core of the Sun energy is produced by nuclear fusion. Once the Sun has used all its nuclear fuel it will collapse to form a white dwarf.

A star with a mass much larger than that of the Sun will end its life in an enormous explosion called a supernova. The energy released in a supernova explosion is more than a hundred times the energy that the Sun will radiate over its entire 10 billion year lifetime.

In our galaxy, the star Betelgeuse is predicted to explode in a supernova. Betelgeuse has a mass of around 8 times the mass of the Sun. Even though Betelgeuse is 640 light-years from Earth, the supernova will be as bright as a full moon at night in our sky.

(a) State what is meant by the term *nuclear fusion*. 1

(b) Determine the average temperature of the surface of the Sun in degrees Celsius. 1

Space for working and answer

MARKS

DO NOT
WRITE IN
THIS
MARGIN

13. (continued)

(c) Show that the distance from Earth to Betelgeuse is 6.1×10^{18} m.

3

Space for working and answer

(d) Betelgeuse may have already exploded in a supernova.

Explain this statement.

1

[END OF QUESTION PAPER]



* X 7 5 7 7 5 0 1 3 1 *

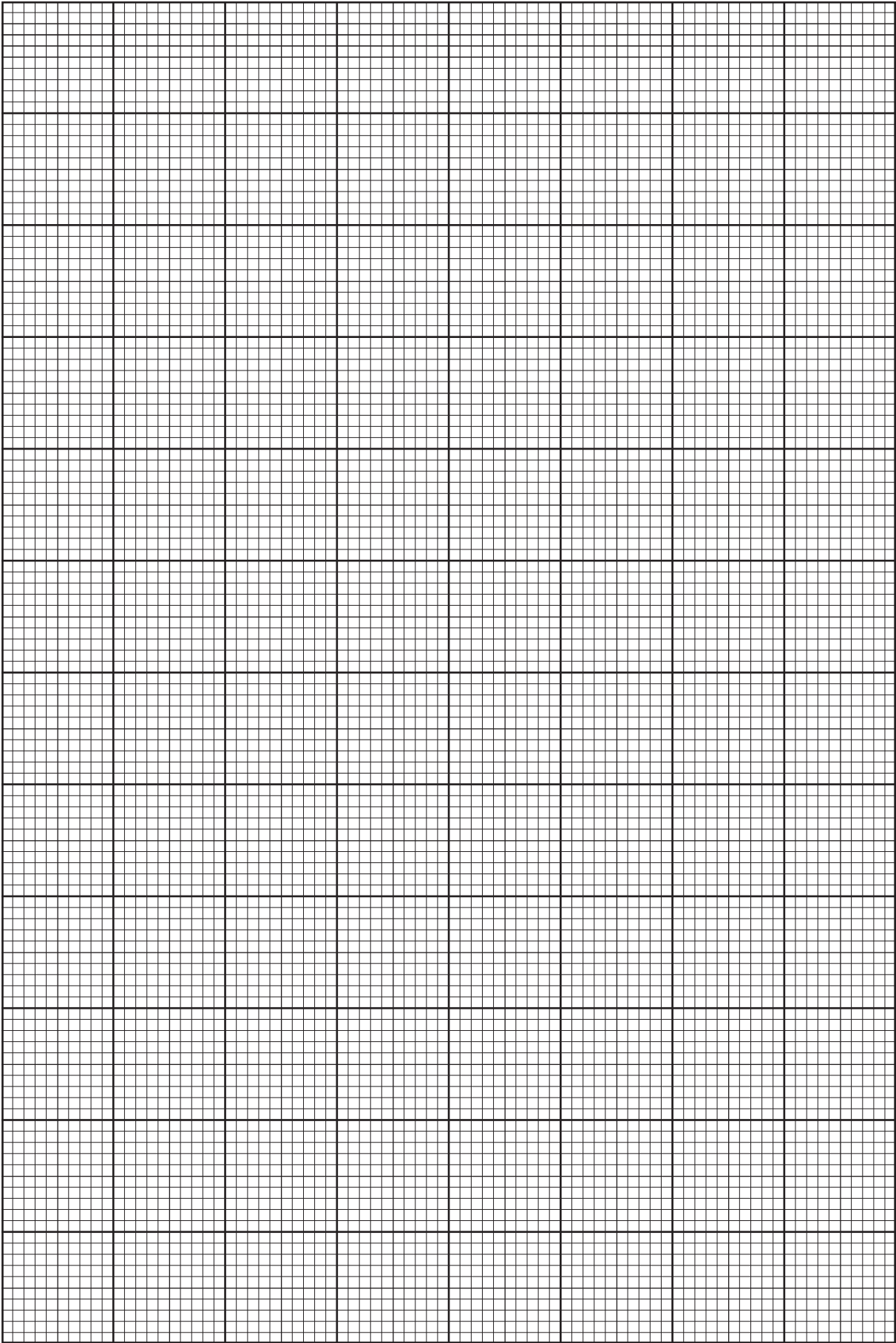

* X 7 5 7 7 5 0 1 3 2 *

ADDITIONAL SPACE FOR ANSWERS AND ROUGH WORKING

Additional diagram for Q2 (a)

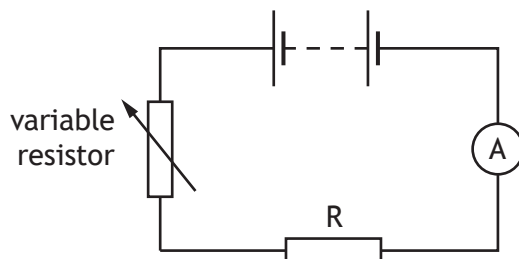

Additional diagram for Q6 (a)

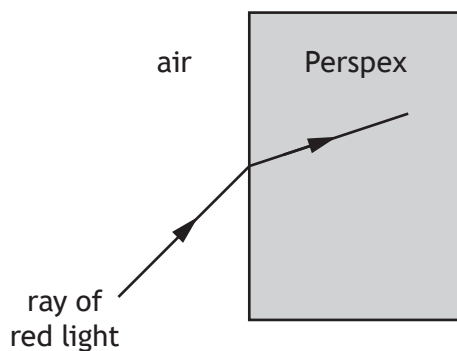

Additional diagram for Q10 (c)

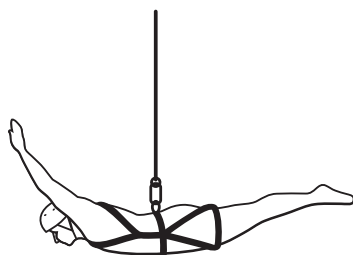



MARKS DO NOT
WRITE IN
THIS
MARGIN

ADDITIONAL SPACE FOR ANSWERS AND ROUGH WORKING

--



* X 7 5 7 7 5 0 1 3 4 *



MARKS DO NOT
WRITE IN
THIS
MARGIN

ADDITIONAL SPACE FOR ANSWERS AND ROUGH WORKING

--



* X 7 5 7 7 5 0 1 3 5 *

ACKNOWLEDGEMENTS

Section 2 Question 1 – Piotr Krzeslak/shutterstock.com

Section 2 Question 13 - AstroStar/shutterstock.com





National
Qualifications
2016

X757/75/11

**Physics
Relationships Sheet**

TUESDAY, 24 MAY

1:00 PM — 3:00 PM



* X 7 5 7 7 5 1 1 *

$$E_p = mgh$$

$$E_k = \frac{1}{2}mv^2$$

$$Q = It$$

$$V = IR$$

$$R_T = R_1 + R_2 + \dots$$

$$\frac{1}{R_T} = \frac{1}{R_1} + \frac{1}{R_2} + \dots$$

$$V_2 = \left(\frac{R_2}{R_1 + R_2} \right) V_s$$

$$\frac{V_1}{V_2} = \frac{R_1}{R_2}$$

$$P = \frac{E}{t}$$

$$P = IV$$

$$P = I^2 R$$

$$P = \frac{V^2}{R}$$

$$E_h = cm\Delta T$$

$$p = \frac{F}{A}$$

$$\frac{pV}{T} = \text{constant}$$

$$p_1 V_1 = p_2 V_2$$

$$\frac{p_1}{T_1} = \frac{p_2}{T_2}$$

$$\frac{V_1}{T_1} = \frac{V_2}{T_2}$$

$$d = vt$$

$$v = f\lambda$$

$$T = \frac{1}{f}$$

$$A = \frac{N}{t}$$

$$D = \frac{E}{m}$$

$$H = Dw_R$$

$$\dot{H} = \frac{H}{t}$$

$$s = vt$$

$$d = \bar{v}t$$

$$s = \bar{v}t$$

$$a = \frac{v-u}{t}$$

$$W = mg$$

$$F = ma$$

$$E_w = Fd$$

$$E_h = ml$$

Additional Relationships

Circle

$$\text{circumference} = 2\pi r$$

$$\text{area} = \pi r^2$$

Sphere

$$\text{area} = 4\pi r^2$$

$$\text{volume} = \frac{4}{3}\pi r^3$$

Trigonometry

$$\sin \theta = \frac{\text{opposite}}{\text{hypotenuse}}$$

$$\cos \theta = \frac{\text{adjacent}}{\text{hypotenuse}}$$

$$\tan \theta = \frac{\text{opposite}}{\text{adjacent}}$$

$$\sin^2 \theta + \cos^2 \theta = 1$$

Electron Arrangements of Elements

Group 1 Group 2
(1)

1 H Hydrogen	4 Be Beryllium
3 Li Lithium	2,2 Ba Barium
2,8,1 Na Sodium	2,8,2 Mg Magnesium
19 K Potassium	2,8,8,2 Ca Calcium
2,8,18,8,1 Rb Rubidium	2,8,18,8,2 Sr Strontium
2,8,18,18,8,1 Cs Caesium	2,8,18,18,8,2 Ba Barium
87 Fr Francium	2,8,18,32,18,8,1 Ra Radium

Key

Atomic number
Symbol
Electron arrangement
Name

Transition Elements

21 Sc Scandium	22 Ti Titanium	23 V Vanadium	24 Cr Chromium	25 Mn Manganese	26 Fe Iron	27 Co Cobalt	28 Ni Nickel	29 Cu Copper	30 Zn Zinc
39 Y Yttrium	40 Zr Zirconium	41 Nb Niobium	42 Mo Molybdenum	43 Tc Technetium	44 Ru Ruthenium	45 Rh Rhodium	46 Pd Palladium	47 Ag Silver	48 Cd Cadmium
57 La Lanthanum	72 Hf Hafnium	73 Ta Tantalum	74 W Tungsten	75 Re Rhenium	76 Os Osmium	77 Ir Iridium	78 Pt Platinum	79 Au Gold	80 Hg Mercury
89 Ac Actinium	104 Rf Rutherfordium	105 Db Dubnium	106 Sg Seaborgium	107 Bh Bohrium	108 Hs Hassium	109 Mt Meitnerium	110 Ds Darmstadtium	111 Rg Roentgenium	112 Cn Copernicium

Lanthanides

57 La Lanthanum	58 Ce Cerium	59 Pr Praseodymium	60 Nd Neodymium	61 Pm Promethium	62 Sm Samarium	63 Eu Europium	64 Gd Gadolinium	65 Tb Terbium	66 Dy Dysprosium	67 Ho Holmium	68 Er Erbium	69 Tm Thulium	70 Yb Ytterbium	71 Lu Lutetium
------------------------------	---------------------------	---------------------------------	------------------------------	-------------------------------	-----------------------------	-----------------------------	-------------------------------	----------------------------	-------------------------------	----------------------------	---------------------------	----------------------------	------------------------------	-----------------------------

Actinides

89 Ac Actinium	90 Th Thorium	91 Pa Protactinium	92 U Uranium	93 Np Neptunium	94 Pu Plutonium	95 Am Americium	96 Cm Curium	97 Bk Berkelium	98 Cf Californium	99 Es Einsteinium	100 Fm Fermium	101 Md Mendelevium	102 No Nobelium	103 Lr Lawrencium
-----------------------------	----------------------------	---------------------------------	---------------------------	------------------------------	------------------------------	------------------------------	---------------------------	------------------------------	--------------------------------	--------------------------------	-----------------------------	---------------------------------	------------------------------	--------------------------------

Group 3 Group 4 Group 5 Group 6 Group 7 Group 8
(18)

5 B Boron	6 C Carbon	7 N Nitrogen	8 O Oxygen	9 F Fluorine	10 Ne Neon
13 Al Aluminium	14 Si Silicon	15 P Phosphorus	16 S Sulfur	17 Cl Chlorine	18 Ar Argon
2,8,3 Ga Gallium	2,8,4 Ge Germanium	2,8,5 As Arsenic	2,8,6 Se Selenium	2,8,7 Br Bromine	2,8,8 Kr Krypton
2,8,18,3 In Indium	2,8,18,4 Sn Tin	2,8,18,5 Sb Antimony	2,8,18,6 Te Tellurium	2,8,18,7 I Iodine	2,8,18,8 Xe Xenon
2,8,18,18,3 Tl Thallium	2,8,18,18,4 Pb Lead	2,8,18,18,5 Bi Bismuth	2,8,18,18,6 Po Polonium	2,8,18,18,7 At Astatine	2,8,18,18,8 Rn Radon